

ProTungsten Air

User's Guide EN

This user guide is available in other languages at profoto.com/support

CN – 其他语言版本的用户指南可从profoto.com/cn/support下载

DE – Das Bedienungs-Handbuch is auch in anderen Sprachen verfügbar unter profoto.com/de/support

ES – Esta guía de usuario está disponible en otros idiomas en profoto.com/support

FR – Ce manuel d'utilisation est également disponible en d'autres langues sur profoto.com/fr/support

IT – Questa guida per gli utenti è disponibile in altre lingue su profoto.com/it/support

JP – このユーザーガイドはprofoto.com/ja/supportに他の言語でもご用意しています。

RU – Инструкция пользователя на других языках доступна на profoto.com/ru/support



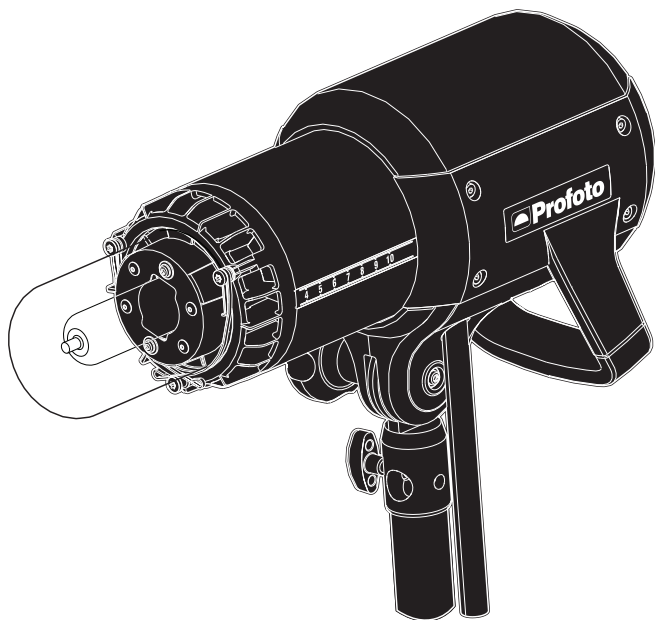

Thank you for choosing Profoto

Thanks for showing us your confidence by investing in a ProTungsten Air unit. For more than four decades we have sought the perfect light. What pushes us is our conviction that we can offer even yet better tools for the most demanding photographers. Before our products are shipped we have them pass an extensive and strict testing program. We check that each individual product comply with specified performance, quality and safety. For this reason our flash equipment is widely used in rental studios and rental houses worldwide, from Paris, London, Milan, New York, Tokyo to Cape Town.

Some photographers can tell just from seeing a picture, if Profoto equipment has been used.

Professional photographers around the world have come to value Profoto's expertise in lighting and light-shaping. Our extensive range of Light Shaping Tools offers photographers unlimited possibilities for creating and adjusting their own light.

Every single reflector and accessory creates its special light and the unique Profoto focusing system offers you the possibility to create your own light with only a few different reflectors.

Enjoy your Profoto product!

Safety instructions



SAFETY PRECAUTIONS!

Read and follow all safety instructions below carefully to avoid injuries or damages! Make sure that Profoto Safety Instructions is always accompanied the equipment! Profoto products are intended for professional use! The equipment is only intended for indoor photographic use. Do not place or use the equipment where it can be exposed to moisture, extreme electromagnetic fields or in areas with flammable gases or dust! Do not use the equipment in ambient temperature higher than +35 °C (+95 °F). Do not expose the equipment to dripping or splashing. Do not place any objects filled with liquids on or near the equipment. Do not expose the equipment to hasty temperature changes in humid conditions as this could lead to condensation water in the unit. Do not connect this equipment to equipment from other brands. Only use lamps and light shaping tools as specified by Profoto. Do not use lamp without supplied protective glass covers or protective grids. Do not stare directly at lamp while in operation. Minimum distance to flammable surfaces is 200 cm in front of the lamp. Limit exposure in front of the lamp if used at close distances. Glass covers shall be changed if it has become visibly damaged to such an extent that their effectiveness is impaired, for example by cracks or deep scratches. Lamps shall be changed if they are damaged or thermally deformed. When placing a lamp into the holder ensure not to touch the bulb with bare hands. Equipment must only be serviced, modified or repaired by authorized and competent service personnel!



WARNING – Electrical Shock – High Voltage!

The equipment shall always be connected to grounded mains power supply outlet! Only use Profoto extension cables and mains cables! Do not open or disassemble lamp head! Equipment operates with high voltage. Disconnect power cable when changing bulb!



Caution – Burn Hazard – Hot Parts!

Do not touch hot parts with bare fingers! Bulb, protective glass cover and certain metal parts emit strong heat when used! Reflector parts may reach a temperature of +200 °C (+392 °F). When the lamp has been in use, wait 10 minutes before removing the protective glass cover. Do not point lamp too close to persons. All lamps may on rare occasions explode and throw out hot particles! Make sure that rated voltage for modeling lamp corresponds with technical data of user guide regarding power supply!

NOTICE

NOTICE – Equipment Overheating Risk

Remove transport cap from lamp head before use! Do not obstruct ventilation by placing filters, diffusing materials, etc. over inlets and outlets of the equipment ventilation or directly over protective glass cover.

Note about RF!

This equipment makes use of the radio spectrum and emits radio frequency energy. Proper care should be taken when the device is integrated in systems. Make sure that all specifications within this document are followed, especially those concerning operating temperature and supply voltage range. Make sure the device is operated according to local regulations. The frequency spectrum this device is using is shared with other users. Interference can not be ruled out.



Final Disposal

Equipment contains electrical and electronic components that could be harmful to the environment. Equipment may be returned to Profoto distributors free of charge for recycling according to WEEE. Follow local legal requirements for separate disposal of waste, for instance WEEE directive for electrical and electronic equipment on the European market, when product life has ended!

Table of Contents

System description	7
Profoto Air	7
Nomenclature	8
Functionality	9
Glass cover	9
Power supply	9
Reflector	9
Light intensity	9
Remote control	9
Cooling system	10
Built-in timers	10
Operating instructions	11
Stand mounting	11
Remove protecting cap	11
Changing glass cover	11
Reflector mounting	12
Power connection	12
Radio settings	12
Cooling setting	12
Adjusting light intensity	13
Read out firmware version and timer value	13
Changing settings in standby mode	13
Turn unit off	13
Remote control	14
Turn unit on/off	14
Light intensity setting	14
Maintenance	15
Changing lamp	15
Changing fuse	15
Trouble shooting	16
List of compatible Profoto Light Shaping Tools	17
Technical data	18
Warranty	18
Regulatory information	19
Declaration of Conformity – ProTungsten Air	19

Unites States and Canada	20
F.C.C. and Industry Canada	20
Warning (Part 15.21).....	20
Japan	21

System description

ProTungsten Air is a halogen based continuous light source, with dimming capability from 100 % down to 10 %.

The ProTungsten Air is designed for heavy-duty use. Its metal housing and all components are solid, reliable and withstand even the most demanding shooting situations.

As a professional photographer or videographer, you have your own special style and needs. Profoto's Light Shaping Tools – including the new line of Light Shaping Tools for Video Lights – fit perfectly with the ProTungsten Air, enabling you to shape the light your own way.

7

Profoto Air

Profoto Air is a system for convenient remote control of flash generators and studio lamps. The Profoto Air system is operating on one of eight selectable radio channels on the 2.4 GHz radio frequency band, for world wide use. Profoto Air allows control of your light from as far away as 300 m/1000 ft (free line of sight).

The Profoto Air radio system is fully integrated in the ProTungsten Air.

Profoto Air Remote

The Profoto Air Remote device offers remote control of your ProTungsten Air unit. The device controls practically an infinite number of ProTungsten Air units in up to six groups, either all at once in Master mode, or in individual groups.

Nomenclature

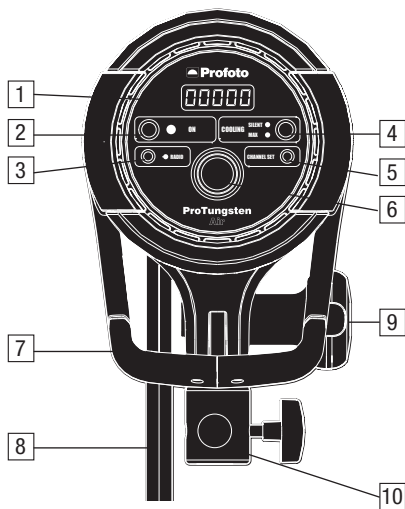

- | | |
|---------------------|----------------------------|
| 1. Display | 4b. Silent Indicator |
| 2. POWER CONTROL | 4c. Max Indicator |
| 2a. On/Off Button | 5. Channel Set Button |
| 2b. Power Indicator | 6. Setting Knob |
| 3. RADIO CONTROL | 7. Handle |
| 3a. Radio Button | 8. Power Cable |
| 3b. Radio Indicator | 9. Locking Knob |
| 4. COOLING CONTROL | 10. Stand Adapter |
| 4a. Cooling Button | 11. Protective glass cover |
| | 12. Zoom Scale |

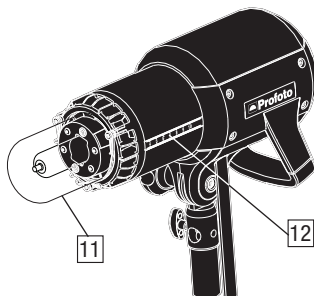

Functionality

Glass cover

The ProTungsten Air unit is equipped with a protective glass cover, which protects from lamp shatter. Unless the glass cover is correctly mounted (see page 11) it is not possible to turn on the ProTungsten Air unit.



SAFETY PRECAUTION!

A damaged (cracked or scratched) glass cover must never be used! Only use Profoto specified lamps.

The protective glass cover is available in different versions; with frosted and clear glass.

Power supply

The ProTungsten Air unit can be connected to any mains voltage between 100-240VAC, 50 or 60 Hz. The power supply fuse must not be smaller than specified in the section *Technical data*.

NOTICE **NOTICE** – Always make sure that the rated voltage of the bulb corresponds with mains voltage!

Reflector

By mounting a reflector and placing it in different positions, using the Zoom Scale [12], several light shapes can be created for each lighting purpose. The unique rubber collar fastening system provides secure and rapid handling of the reflectors, also when hot.

Light intensity

The current light intensity is shown in the Display [1], in percent (%) of maximum light output.

The Setting Knob [6] is used to adjust the light intensity, in 1 % or 10 % increments.

Remote control

The Profoto Air radio system is fully integrated in the ProTungsten Air unit, allowing wireless remote control.

With the Profoto Air Remote device, the ProTungsten Air unit can be turned on/off remotely and the light intensity can be adjusted. With the Profoto Studio Air software, multiple lighting setups including numerous continuous lights and flash units can be created and coordinated.

For more information about remote control, please refer to the User's Guides for Profoto Air Remote or Profoto Air USB/Profoto Studio Air.

Cooling system

The ProTungsten Air unit is equipped with an state-of-the-art cooling system, designed for optimal cooling without generating unwanted noise.

The cooling system includes automatic overheating protection. If the temperature of the ProTungsten Air unit exceeds maximum set levels, the ProTungsten Air unit will be turned off. This automatic protection will only interfere under extreme conditions, such as when the air vents are blocked.

Built-in timers

The lamp has a built-in timer, which can be read out and reset in standby mode. The timer feature is included to make it easier to keep track of lamp life.

There is also another timer, which can not be reset from the panel interface. This timer can only be read out and reset via the Profoto Air system.

Operating instructions

Stand mounting

1. Mount and fasten the ProTungsten Air unit on the stand using the locking knob on the Stand Adapter [10].
2. The unit can be directed upwards/downwards when the Locking Knob [9] is loosened. Fasten the Locking Knob [9] when the unit is correctly directed.

Remove protecting cap

1. Unlock the clasp on the protecting cap.
2. Gently remove the protecting cap from the ProTungsten Air unit.

Changing glass cover

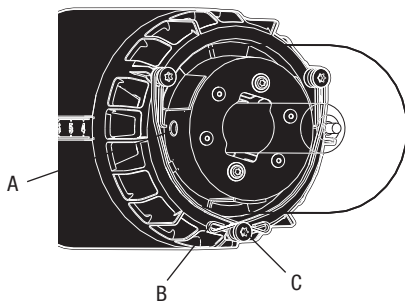

1. Ensure that the ProTungsten Air unit is turned off and that the Power Cable [8] is not connected.
2. If the ProTungsten Air unit has been in use, wait for the unit to cool down or use protective gloves.
3. Unlock the glass cover by lifting the safety pins [B] one by one out from the bottom screw [C].
4. Gently remove the glass cover and fit the new glass cover in place.
5. Make sure that both safety pins fit properly into the holes [A] on each side of the glass cover.
6. Secure the glass cover by pressing the safety pins one by one under the top screw.

Reflector mounting

1. Unlock the clasp on the reflector.
2. Slide the reflector onto the ProTungsten Air unit. Use the Zoom Scale [12] to place the reflector in the desired position.
3. Secure the reflector by locking the clasp.

Power connection

1. Connect the Power Cable [8] to mains power supply.
2. The Power Indicator [2b] will be red, indicating that the unit is receiving power but is in standby mode.
3. Press the On/Off Button [2a].
4. The Power Indicator [2b] will now be green.

Radio settings

1. Activate the built-in radio transceiver by pressing the Radio Button [3a] and verify that the Radio Indicator [3b] is illuminated (green).
2. Press the Channel Set Button [5]. The Display [1] will start flashing, showing the current radio channel number to the left and the radio group letter to the right.
3. While the Display [1] is flashing, turn the Setting Knob [6] clockwise to increase the radio channel number (1 to 8) and counter-clockwise to decrease the number.
4. While the Display [1] is flashing, press and hold down and turn the Setting Knob [6] clockwise to increase the group letter (A to F) and counter-clockwise to decrease the letter.
5. Wait until the Display [1] stops flashing. (The Display [1] will now show the light intensity.)

Cooling setting

The Cooling Button [4a] is used to select cooling mode:

- SILENT: “Normal” cooling. In this mode the cooling adapts to the ambient environment, keeping the noise level to a minimum without risking overheating of the equipment.
- MAX: Maximum cooling is provided for lamp and accessories. This mode is intended for use only when sound level is not an issue and the lamp is operated under extreme temperature conditions.

Adjusting light intensity

Use the Setting Knob [6] to adjust the light intensity:

- Turn the Setting Knob [6] clockwise to increase the light intensity in 1% increments and counter-clockwise to decrease.
- Press and hold down the Setting Knob [6] and turn the knob clockwise to increase the energy in 10% increments and counter-clockwise to decrease.

Read out firmware version and timer value

To read out the firmware revision and timer value, the lamp must be in standby mode.

1. Press and hold the Setting Knob [6] for 1 second, then release the knob.
2. The timer value in hours will now be displayed.
3. Toggle between the timer value and the firmware revision by turning the Setting Knob [6] clockwise and counter-clockwise.
4. Reset the timer value by pressing the Channel Set Button [5].
5. Return to standby by pressing the Setting Knob [6].

Changing settings in standby mode

All settings on the lamp can be reached and changed in standby mode. A short press on the Setting Knob [6] will light up the settings and make it possible to change the radio and cooling settings values.

Turn unit off

1. Press the On/Off Button [2a] to turn off the ProTungsten Air unit.
2. The Power Indicator [2b] will be red, indicating that the unit is receiving power but is in standby mode.
3. Disconnect the Power Cable [8] from mains power.

Remote control

For remote control using Profoto Air Remote, the same radio channel and group have to be set on the ProTungsten Air unit and the Profoto Air device.

For remote control using Profoto Air USB and Profoto Studio Air, the same radio channel has to be set on the ProTungsten Air unit and in the Profoto Studio Air program.

For radio channel and group settings on the Profoto Air devices and the Profoto Studio Air program, please refer to the corresponding User's Guide.

Turn unit on/off

Use the Head or Model Buttons (1) and (0) on the Profoto Air Remote device to turn the ProTungsten Air unit on and off.

Light intensity setting

Use the Energy Buttons (+) and (-) on the Profoto Air Remote device to increase/decrease the light intensity:

- Press the Energy Button < 2 seconds to increase/decrease in 1% increments.
- Press the Energy Button > 2 seconds to increase/decrease in 10% increments.

Maintenance

Changing lamp



SAFETY PRECAUTION!

Do not touch lamp bulb with bare hands. Cleaning cloth is included with Profoto supplied bulb.

1. Ensure that the Power Cable [8] is not connected.
2. If the ProTungsten Air unit has been in use, wait for the unit to cool down.
3. Unlock the glass cover by lifting the safety pins one by one out from the top screw, see figure on page 11.
4. Gently remove the glass cover.
5. Pull the lamp bulb straight out of the socket. Always use protective gloves when doing this.
6. Insert a new lamp bulb, straight into the socket. Do not touch the bulb with bare hands.
7. Gently fit the glass cover in place.
8. Make sure that the circuit breaker is pressed down and that both safety pins fit properly into the slots on each side of the glass cover, see figure on page 11.
9. Secure the glass cover by pressing the safety pins one by one under the top screw.

Changing fuse

There is one exchangeable fuse in the mains inlet on the Power Cable [8].

1. Disconnect the Power Cable [8] from mains power.
2. Pull out the fuse holder on the mains inlet and remove the old fuse.
3. Gently push the new fuse all the way into the fuse holder. Only use fuses specified in section *Technical data*.
4. Gently push the fuse holder in place.

Trouble shooting

Symptom	Diagnose	Action
Power Indicator [2b] not illuminated	Bad connection to AC mains	<ul style="list-style-type: none">• Check that the Power Cable [8] is correctly connected.
	Internal fuse defect	<ul style="list-style-type: none">• Check the fuse. If the problem remains after replacing the fuse, contact your nearest Profoto service station.
The ProTungsten Air unit turns off automatically	The unit is overheated	<ul style="list-style-type: none">• Ensure better ventilation.• Wait until the temperature decreases before the unit is turned on again.• If the problem remains please contact your nearest Profoto service station.

List of compatible Profoto Light Shaping Tools

The ProTungsten Air can be used in combination with the following Profoto light shapers:

- HR Softboxes
- HR Lanterns, except 1.3x1.8 RF (40x50cm), HR Lantern 1.7' FLAT (Max 400W)
- Cine reflector including lenses
- Softlight reflector
- Magnum reflector
- Zoom reflector
- Narrow beam reflector
- Narrow beam travel reflector
- Wide Zoom reflector
- Tele Zoom reflector
- ProTube
- Disc reflector
- ProFresnel Spot
- Profoto Giant reflectors (parabolic)
- Profoto Silver umbrellas (with Cine reflector only).
- Profoto Translucent umbrellas (with Cine reflector only).

The ProTungsten Air is not recommended to be used with the following Profoto Light shapers:

- Profoto white umbrellas
- Grids
- Standard softboxes
- Hardbox
- ProBox
- Fresnel Small
- Spot Small
- ProGlobe
- Snoot
- Grid and filter holder
- Diffusers for Giant reflectors

Technical data

Wattage	500 W or 1000 W
Lamp type	FEL (120V, 1000W) FEP (240V, 1000 W) Other types also available. Contact your Profoto dealer for specific information of bulb availability
Socket type	G 9.5
Lamp life	Approx. 250 hours
Color temperature	(max) 3200 K
Dimming	10-100 % (~ 4 f-stops)
Input voltage	100-240V, 50/60 Hz
Fuse	10A, Fast acting type, 5 x 20 mm (F10AH250V)
Dimensions	39 x 13 x 18 cm (15 x 5 x 7 in)
Weight	2.7 kg (6 lbs) without cable

All data are to be considered as nominal and Profoto reserves the right make changes without further notice.

Warranty

All Profoto products are individually tested before they leave the company and guaranteed for a period of two years with the exception of flash tubes, glass covers, modeling lamps, batteries and cables. Profoto is not responsible for technical malfunctions created by improper use or accessories made by other companies. If you have any technical problems please get in contact with an authorized Profoto service station. The Warranty is subject to and shall be interpreted in accordance with the law of the country where the product is purchased.

Regulatory information

Declaration of Conformity – ProTungsten Air

The ProTungsten Air has been designed to conform to the relevant parts of the European directives Low Voltage Directive (LVD) 2006/95/EC and EMC Directive 2004/108/EC.

The ProTungsten Air is a light armature for photographic purposes.

Manufacturer: Profoto AB

Address: Box 2021, 128 21 SKARPNÄCK, Sweden

Product: ProTungsten Air

Profoto declared that the product complies with the essential requirements of Low Voltage Directive (LVD) 2006/95/EC and EMC Directive 2004/108/EC.

For the evaluation of compliance, applicable parts of standard SS-EN 60598-1 have been applied.

Skarpnäck, March 2011



Bo Dalenius, VP Technology and QA,
Profoto AB

Unites States and Canada

F.C.C. and Industry Canada

Compliance Statement (Part 15.19)

This device complies with Part 15 of FCC rules and RSS-210 of Industry Canada.

Operation is subject to the following two conditions:

- 1) this device may not cause harmful interference and,
- 2) this device must accept any interference received, including interference that may cause undesired operation.



20

Warning (Part 15.21)

Changes or modifications not expressly approved by the party responsible for compliance could void the user's authority to operate the equipment.

Ce dispositif est conforme aux normes RSS-210 d'Industrie Canada.

L'utilisation de ce dispositif est autorisée seulement aux conditions suivantes :

- 1)il ne doit pas produire de brouillage et
- 2)l'utilisateur du dispositif doit être prêt à accepter tout brouillage radioélectrique reçu, même si ce brouillage est susceptible de compromettre le fonctionnement du dispositif.

The term 'IC' before the certification/registration number only signifies that the Industry Canada technical specifications were met.

Les lettres 'IC' n'ont aucune autre signification ni aucun autre but que d'identifier ce qui suit comme le numéro de certification/d'enregistrement d'Industrie Canada.

Profoto AB

Transmitter / Receiver

MODEL: Profoto Air RMI

PRODUCT NO: PNZ1808-0000

FCC ID: W4G-RMI

IC: 8167A-RMI

Made in Sweden

Japan

The module has been granted modular approval for sale and operation in Japan.

特定無線設備の種類

Classification of specified radio equipment:

Article 2, Clause 1, Item 19

2.4 GHz Wide Band Low Power Data Communication

上記のとおり、電波法第38条の24第1項の規定に基づく認証を行ったものであることを証する。

This is to certify that the above-mentioned certification by type has been granted in accordance with the provisions of Article 38-24, Paragraph 1 of the Radio Law.

In order to comply with Japanese regulations the output power must be limited to 10 dBm and any user access to the RF-parts must be hindered by using:

- An enclosure that needs special tools to open
- An RF-shield that protects the transceiver, amplifier and VCO.

The product must be labelled with the following registration number:



® 202WW08109201

Technical data and product information are subject to change without notice.

xxxxxx-x. Printed in Sweden.

Profoto AB

P.O. Box 1264

SE-172 65 Sundbyberg, SWEDEN

Visiting address:

Landsvägen 57, Sundbyberg

Phone +46 8 447 53 00

info@profoto.com

www.profoto.com



Profoto®
The Light Shaping Company™